

# Winnipeg Sewage Treatment Program Integrated Management System



## Drawing Content

**DOCUMENT NUMBER: PG-RC-PC-06**

Rev	Prepared by	Reviewed by	Date	Approved by	Date
2014-11-06	Curtis Reimer				

## TABLE OF CONTENTS

1	Introduction .....	3
1.1	Scope of the Document .....	3
1.2	Definitions.....	3
2	Drawing Title Block .....	4
3	Drawing Content .....	6
4	Drawing Lifecycle Management.....	8
4.1	Drawing Lifecycle Class .....	8
4.2	New Drawings .....	9
4.3	Existing Drawings – Revision and Replacement.....	9
5	Authentication of Drawings .....	11
5.1	General.....	11
5.2	Electronic File Format of Authenticated Drawings .....	12
5.3	Drawing Revisions .....	12
5.4	Superseded Drawings .....	13

# 1 INTRODUCTION

## 1.1 Scope of the Document

This document outlines the requirements associated with technical drawing content and revision procedure. It will ensure that drawings are produced with content in a similar fashion, regardless of the source of the document.

This document shall be applicable to all work performed under the Winnipeg Sewage Treatment Program (WSTP).

## 1.2 Definitions

APEGM	Association of Professional Engineers and Geoscientists of Manitoba
Superseded drawing	A drawing that has been replaced by a newer drawing. The existing drawing shall be modified to clearly indicate the new drawing that supersedes the existing drawing.
TDNS	Technical Document Numbering System; as per <a href="#">PG-RC-PC-03 Technical Document Numbering Procedure</a>
WSTP	Winnipeg Sewage Treatment Program

## 2 DRAWING TITLE BLOCK

All drawing title blocks shall be completed in a format consistent with Figure 1, Figure 2, and Figure 3 as well as the associated notes.

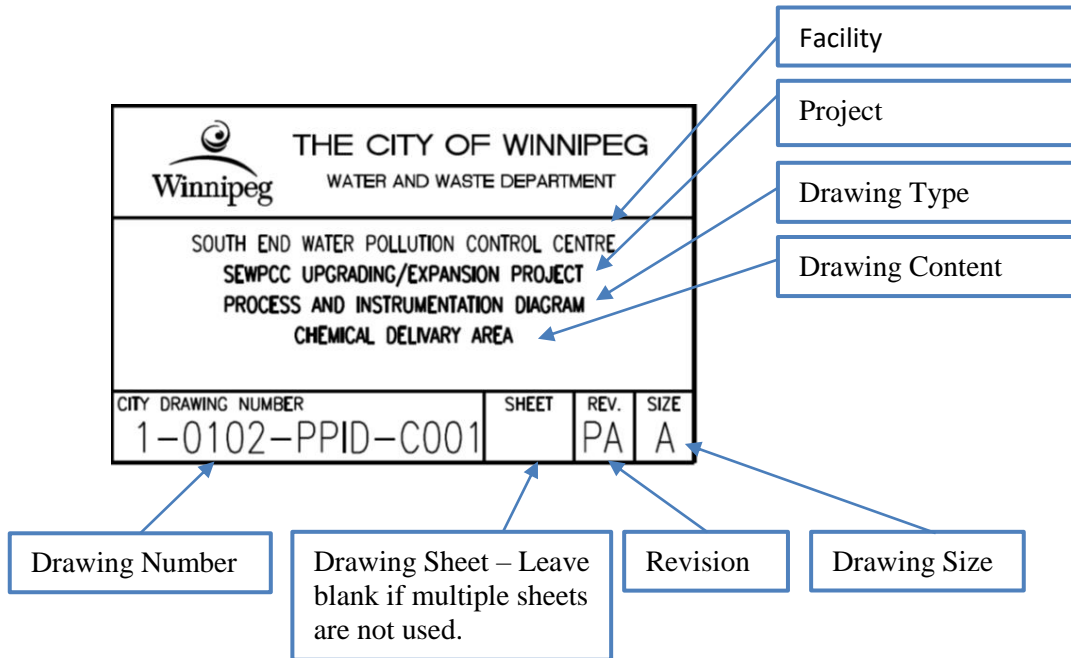

**Figure 1 : Title Block Information – 1**

**Notes:**

1. *The Project shall be the name of the project that the drawing was originally created under. Do not revise the project name when modifying an existing drawing for a subsequent project.*
2. *If drawing sheets are utilized, the Sheet Number shall have 3 digits.*
3. *The Revision code shall have two characters, as per the TDNS.*

DESIGNED BY:	CHECKED BY:
DRAWN BY:	APPROVED BY:
SCALE:	ISSUED FOR CONSTRUCTION BY:
DATE:	
CONSULTANT NO.:	

Designer Logo

Initials and full last name (J.S. SMITH)

**Figure 2 : Title Block Information – 2**

**Notes:**

1. *All names shall include first (and middle if appropriate) initials and the full last name of the person. For example: J.S. SMITH*
2. *All dates shall be in YYYY-MM-DD format. For example: 2014-11-19*
3. *The person in the Designed By box shall be the primary designer of the original drawing content. This may or may not be a professional engineer or architect. This field may be completed at an early stage in the development of the drawing.*
4. *The person in the Drawn By box shall be the primary drafter of the original drawing content. This field may be completed at an early stage in the development of the drawing.*
5. *The person in the Checked By box shall be the primary discipline engineer or architect who has performed a full quality control review of the drawing. This person must be a professional engineer or architect. This field must be completed only after the reviewer has completed the review of the drawings, and appropriately signed off on the drawing content. This field should only be completed when drawings are authenticated.*
6. *The person in the Approved By box shall be the designer's project manager or design team manager who is verifying that the drawing quality control processes have been followed and that the document meets the contractual requirements of the project. This field should only be completed when drawings are authenticated.*
7. *The Scale box shall be filled with the scale (in metric) applicable to the entire drawing. If the drawing is not to scale, "NTS" (Not To Scale) shall be utilized. Where multiple scales are utilized on a drawing, enter "AS NOTED" in the Scale box.*
8. *The Date box shall be the date of the current issue of the drawing, up to the Rev 00 issue. The Date box shall not change after the Rev 00 issue.*
9. *The Issued for Construction box shall be completed with the name and date of the City project manager who is authorizing the release of the drawing for construction. This field may be completed by the designer based upon verified written direction from the City project manager, which shall be retained in the project record.*

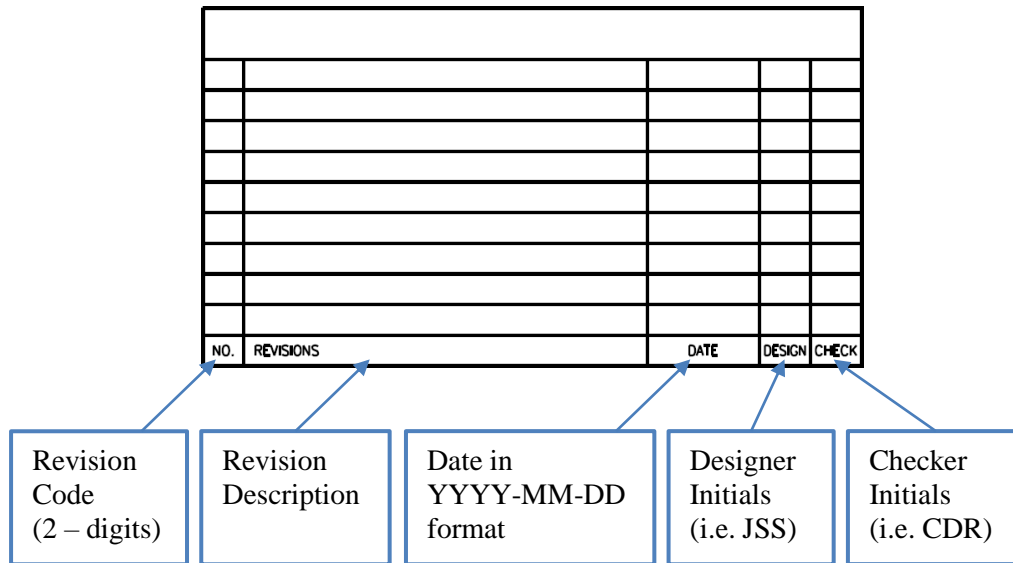

**Figure 3 : Revision Block Information**

**Notes:**

1. *The Revision Description shall be as per XXX*
2. *The person in the Checked By box shall be the primary discipline engineer or architect who has performed a quality control review of the drawing revision. This person must be a professional engineer or architect. This field must be completed only after the reviewer has completed the review of the drawings, and appropriately signed off on the drawing content.*

**Table 1 : Typical Revision Descriptions**

Revision Code	Revision Description	Notes
00	Issued For Construction, B.O XXX-YYYY	If appropriate.
	Issued for Tender, B.O XXX-YYYY	Only use if authorized by the City Project Manager, when not Issued For Construction
01-99	Addendum X, B.O XXX-YYYY	
	PCN?	
	CCO-1, B.O XXX-YYYY	

### 3 DRAWING CONTENT

Drawing content shall be organized in a fashion to allow consistency with procedure [PG-RC-PC-03](#) Technical Document Numbering System. Requirements include the following:

1. The drawing content must be limited to a single facility.
2. The drawing content should typically be organized such that the applicable work shown is limited to a single discipline. Where this is not possible, the D – General discipline code may be utilized.
3. Every reasonable effort must be made to limit the content on the drawing to a single document type, as listed in PG-RC-PC-03. For example, avoid placing fire alarm detector information (FAS) on a cable tray drawing (CTR).
4. The drawing content shall not typically span more than one facility area, as indicated by the Area Code, except where required to show overall facility information at a higher scale. For an example, see Figure 4. Exceptions, where drawing content may span multiple Area Codes are identified in Table 2.

**Figure 4 : Drawing Content – Multiple Area Codes**

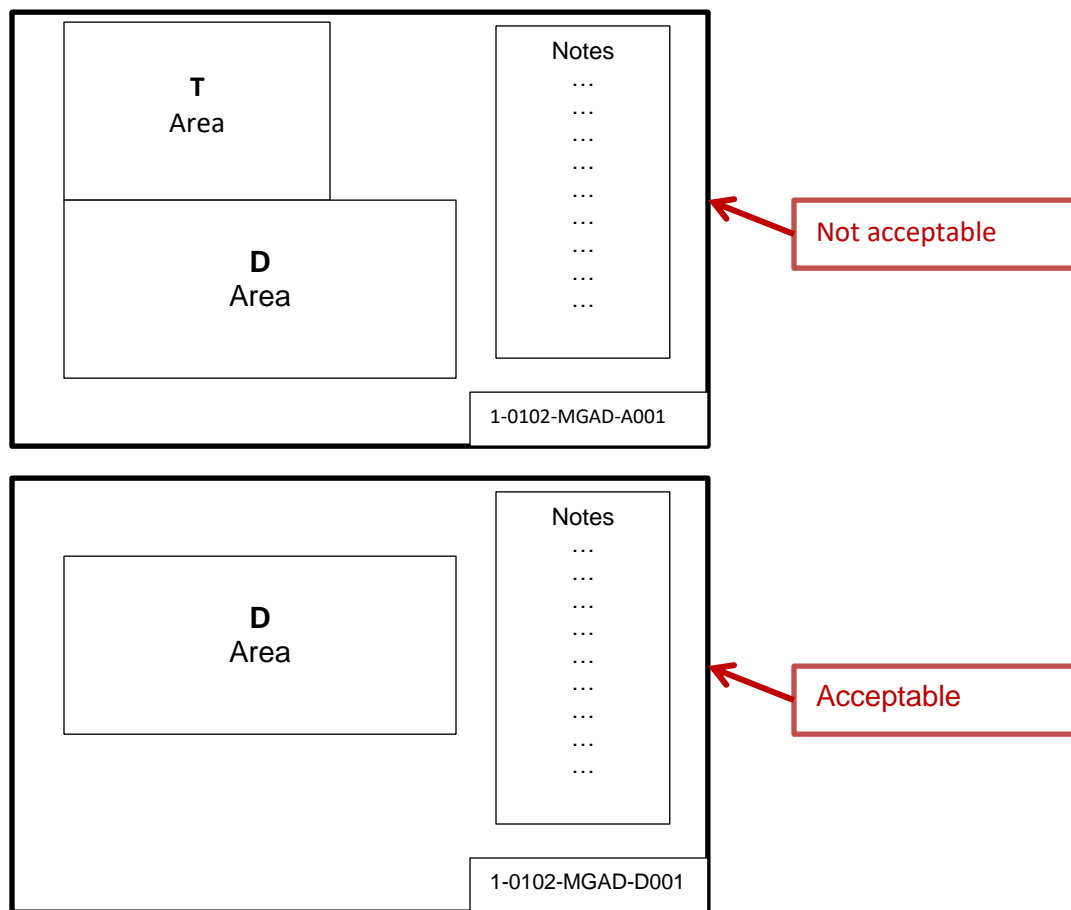
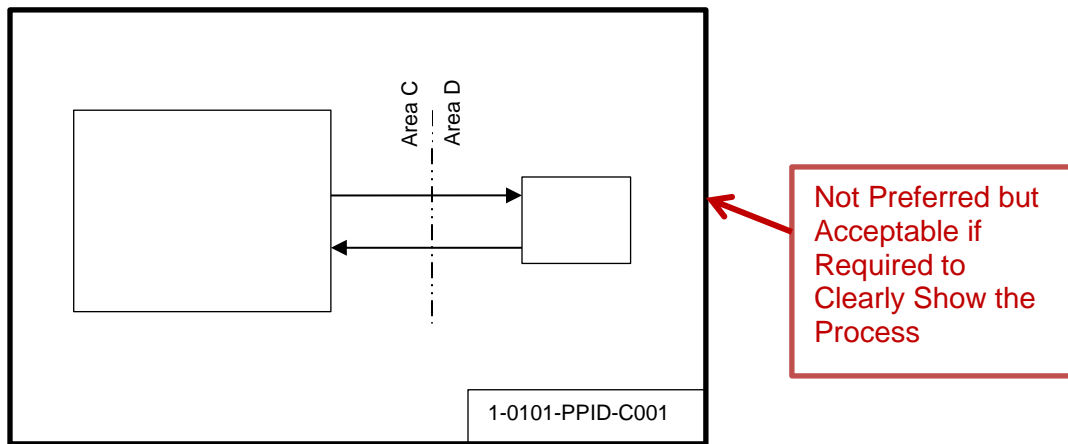

**Table 2 : Acceptable Exceptions Where Multiple Area Codes may be on a Single Drawing**

Discipline	Drawing Type	Notes
Automation	IFS – Instrument Fieldbus Segment Drawings	In some cases, fieldbus segments may cross multiple areas. Separate drawings shall be utilized for fieldbus segments that do not cross area boundaries.

	NET - Networking	Networking drawings shall be arranged by area where practical, but it is acknowledged that some drawings will cross area boundaries.
Electrical	SLD – Single Line Diagrams	Overview single line drawings, which show a high level view of power flow, could span multiple areas. Detailed single line drawings should not generally span multiple areas, although individual loads could be in different areas.
Process	HYD - Hydraulic Profiles	May span multiple areas as required to show the complete profile for the process.
	PFD – Process Flow Diagrams	May span multiple areas if required to show a single process.
	PID – Process and Instrumentation Diagram	Where possible, information shall be grouped by area. However, there may be cases where showing a part of a process, in a different area, may bring unclarity to the design should be made, however a portion of a process may be in a different physical area than shown on the drawing. The drawing number should be classified by the area with the major process components and boundaries of the area on the drawing should be shown using a phantom line, as shown in Figure 5.

**Figure 5 : P&ID Spanning Multiple Areas**



## 4 DRAWING LIFECYCLE MANAGEMENT

### 4.1 Drawing Lifecycle Class

The drawings associated with the WSTP shall be viewed as lifecycle documents for the entire life of the associated asset. As such, decisions regarding drawing creation and content shall consider operations and maintenance implications, as well as any future design modifications, for the life of



any asset shown on the drawing. It is the goal of the WSTP to maintain a comprehensive drawing set for operations and maintenance purposes that accurately represents the current state of each facility. However, it is acknowledged that the various drawings have different requirements from an operations and maintenance perspective. Thus, the following three lifecycle class drawings are defined:

Drawing Lifecycle Class	Description	Examples
1	The drawing is regularly referred to by operations and maintenance personnel upon completion of construction. It is critical that these drawings should be maintained in an organized, updated fashion to allow personnel to easily find the required information.	P&IDs, hydraulic profiles, electrical single line diagrams, loop diagrams
2	The drawing may be utilized by operations and maintenance personnel; however it is not expected that the drawing will be regularly referenced.	Mechanical general arrangement drawings.
3	The drawing is applicable to design and construction and while applicable over the life of the associated asset, the drawing will rarely be utilized by operations and maintenance personnel.	Structural beam detail drawing.

## 4.2 New Drawings

All new drawings shall comply with the following:

1. Drawings shall be numbered as per the TDNS (Technical Document Numbering System).
2. Ensure that the Drawing Type field of the TDNS adequately represents the drawing content. For example, inclusion of a partial P&ID on a process general arrangement drawing is not permitted.

## 4.3 Existing Drawings – Revision and Replacement

When changes are required to an existing installation, a decision must be made whether to modify the existing drawings or supersede / the existing drawings. The decision whether to modify or replace existing drawings shall be made based upon the guideline presented in Table 3.

Rules:

For all major modifications to an existing installation, where ~40% or more of the major design content has changed, a new drawing shall be created with a new drawing number, and the existing drawing superseded.

For all drawings modified, where the existing drawing number does not follow the TDNS, supersede the existing drawing and create a new drawing.

For existing drawings

**Table 3 : Existing Drawing Revision Requirements**

Type of Modification	Drawing Lifecycle Class	Existing Drawing Number Follows TDNS	Action
Major	1/2/3	Y / N	Create new drawing and supersede existing drawing.
Minor	1	N	
		Y	
	2	N	Create new drawing and supersede existing drawing.
		Y	
	3	N	Create new drawing and supersede existing drawing.
		Y	

**Notes:**

1. *Specific items in the contractual scope of work or written instructions from the City take precedence over the above table.*
2. *A major modification would include a revision where over 40% of the drawing content is altered; or the change completely invalidates the original design.*

## ALTERNATE

**Table 4 : Existing Drawing Revision Requirements**

Type of Modification	Existing Drawing Number Follows TDNS	Type of Drawing	Action
Major	N	All	Create new drawing and supersede existing drawing.
	Y		
Minor	N	All	
	Y	Used by Operations or Maintenance (e.g. P&ID, electrical single line)	Revise existing drawing. (Make it easy for staff to reference a consistent drawing number)
		Not Typically used by Operations or Maintenance (e.g. structural beam detail)	Revise existing drawing or create new drawing and supersede existing drawing. Designer discretion may be utilized.

**Notes:**

1. *Specific items in the contractual scope of work or written instructions from the City take precedence over the above table.*
2. *A major modification would include a revision where over 1/3 of the drawing content is altered; or the change significantly invalidates the original design.*

## 5 AUTHENTICATION OF DRAWINGS

### 5.1 General

All design drawings shall be authenticated by a professional engineer. Authentication of drawings shall comply with APEGM guidelines. See:

<http://www.apegm.mb.ca/pdf/Guidelines/AuthenticationOfProfessionalDocuments.pdf>

Drawings shall be authenticated at the following stages:

- Issue for Target Cost Development
  - The drawings shall be clearly noted near the seal with the following note:

Preliminary  
Not For Construction  
For Target Cost Use

- Issue for Tender
- Issue for Construction
  - This will often be the same issue as the Tender issue.
  - The “Issue for Construction” drawings will typically be used for the permitting process
- At any other stage where the documents are relied upon by a 3<sup>rd</sup> party.

Both new drawings and existing drawings that are revised as part of a project shall be authenticated.

## 5.2 Electronic File Format of Authenticated Drawings

Authenticated drawings shall be provided in PDF file format. CAD files are not typically authenticated.

## 5.3 Drawing Revisions

Drawing revisions shall be authenticated. The modified portion of the drawing shall be clouded and marked with a revision triangle, as shown in Figure 6.

**Figure 6 : Drawing Revision Cloud Example**

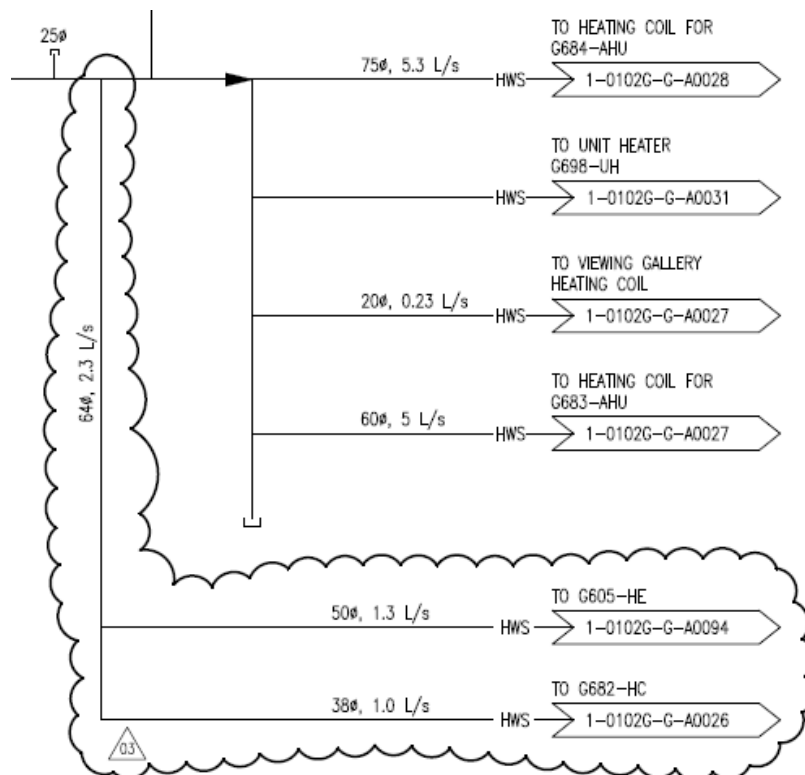

Subsequently, when the drawing is authenticated, a note shall be added indicating the applicable revision that the professional is taking responsibility for, as per Figure 7. The authentication of any previous revisions will no longer be visible on the drawing. The City is responsible for storing previous revisions of drawings, with the corresponding authentication of each revision.

**Figure 7 : Authentication of Drawing Revisions**



## 5.4 Superseded Drawings

When drawings are superseded, the new drawing may contain both existing and new design information. The original and new design content on the drawing must be clarified to avoid uncertainty in design responsibility.

An example of how this may be addressed via notes on the drawing follows:

**Notes:**

1. This drawing supersedes existing drawing NEP-1159.
2. Revision 00 Note: The engineer's design responsibility is limited to the new work indicated by the clouded portion of the drawing.